

LTR	UTILITY	SPEC.	
Ⓜ	WATER PLACEMENT	76 LTR/MIN @ 40 PSI	
Ⓐ	AIR PLACEMENT	12 CFM @ 110 PSI	
Ⓔ	ELECTRICAL PLACEMENT (3 PHASE) 415VAC, 50HZ CUSTOMER TO SUPPLY STARTER	STANDARD 30 HP	DRY CAST 50 HP
		SERVICE REQ'D 60 AMP FLA = 39 AMP	SERVICE REQ'D 100 AMP FLA = 64 AMP

UNIT WEIGHT	
EMPTY	FULL
3200 kg	12900 kg

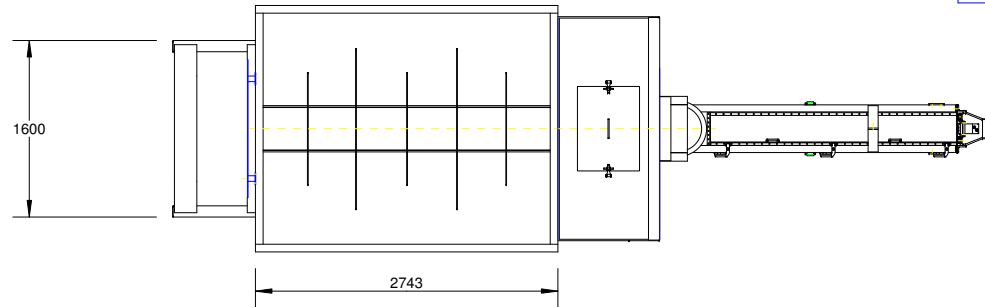

Plan

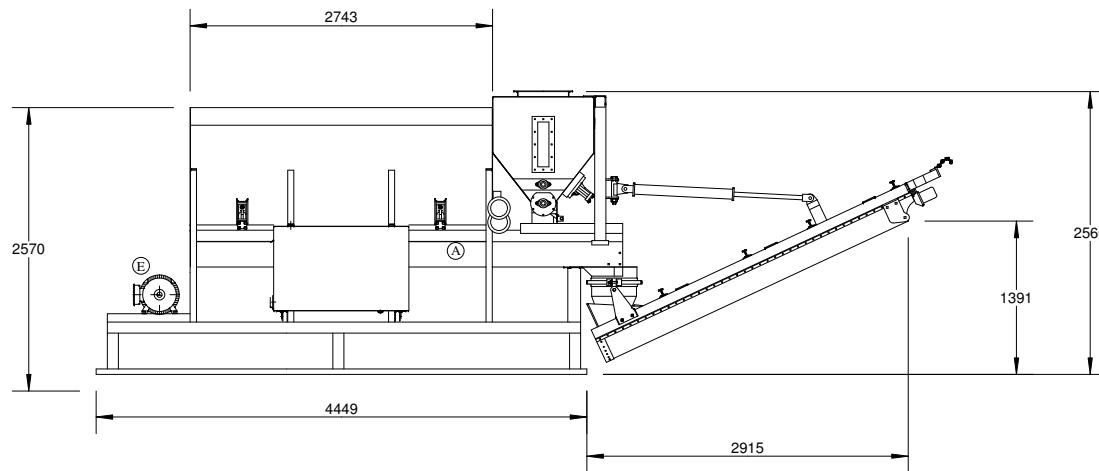

Elevation

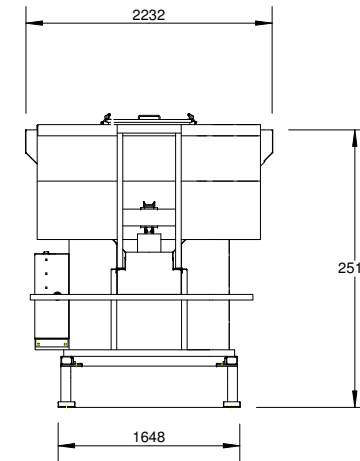

End View

TITLE.	CONCRETE DISPENSER SCD4M-100				
DATE.	15/10/2002	PART No.		COPYRIGHT. This drawing is the property of ARMCON Ltd and must not be Copied or reproduced without Written consent.	
DRG. No.	SCD4M-100	DRG. BY.	R.A.Calder	SCALE	NONE

ARMCON
cementech
EUROPE